

Procedure for joining “Smart Morphing Wing” or “Smart Prosthetics” Senior Design Projects

1 Overview

“Smart Morphing Wing” or “Smart Prosthetics” Senior Design Projects (SDPs) are among the research-based “Smart Systems and Structures” (SSS) SPDs that Dr. Peter L. Bishay founded and is supervising at CSUN’s Mechanical Engineering Department.

1.1 Smart Morphing Wing (SMW)

Smart Morphing Wing (SMW) SDP started in 2016-17 academic year with the goal of designing innovative models of morphing aerodynamic systems such as Unmanned Aerial Vehicle (UAV) with seamless morphing wings and wind turbine blades. Smart materials and structures, such as Shape Memory Alloy (SMA) wires, Macro-Fiber Composite (MFC) patches, corrugated and zero-Poisson-ratio structures, etc. can possibly be integrated in the designs to expand the applications of such new materials and structures. The enrolled students get involved in reading recent research papers on the current advances in this technology, propose analytical and computational models, run computer simulations on their models to justify their designs, physically build their innovative models, test their performance, and present their work at several events such as the American Institute of Aeronautics and Astronautics (AIAA) regional student conference and competition, CSUN’s annual research and creative works symposium (CSUNposium), and CSUN’s Senior Design Project Showcase (SDPS). Preliminary and Critical Design Reviews (PDR and CDR) are also scheduled in the Fall semester, where students get the chance to receive feedback from industry professionals, faculty members, graduate students, and peer undergraduate students. Students also give biweekly presentations and write bimonthly reports throughout the semester.

In its first year (**2016-17**), SMW SDP made the following achievements:

- (1) Five teams presented their research and designs at the AIAA regional student conference at San Jose State University (SJSU). The “Span Morphing” team’s paper entitled “*Design and Manufacturing of a New Span Morphing Wing*” won the **third** place (Award certificates and \$125) in the competition after USC and University of Arizona.
- (2) Five teams presented their research and designs at CSUN’s 21st annual research and creative works symposium (CSUNposium). The “Morphing Winglets” team presentation, entitled “*Integrated Morphing Winglet Design with Shape Memory Alloy Driven Actuation*”, won the **first** place (Award certificates and \$200) in the College of Engineering and Computer Science session of the symposium, while the “Twist

Morphing” team presentation, entitled “*Development of a twist morphing wing design using an SMA based smart soft composite*”, won the **second** place (Award certificates and \$100).

(3) Technical paper on the span morphing wing core design has been published in *designs* journal (MDPI publisher) entitled “*Development of a New Span-Morphing Wing Core Design.*”

http://www.csun.edu/~pbishay/pubs/Bishay_et_al_Designs_MDPI_2019.pdf

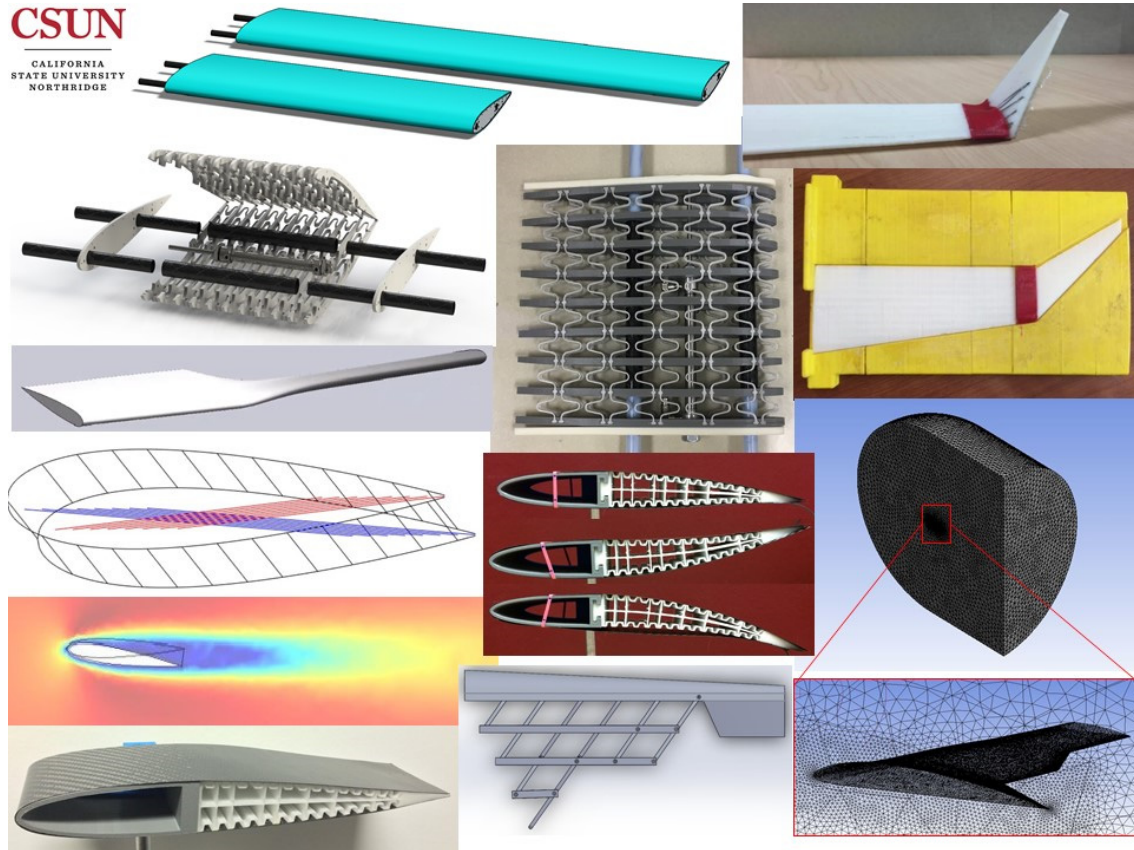

 **designs**



Article

Development of a New Span-Morphing Wing Core Design

Peter L. Bishay *, Erich Burg, Akinwande Akinwunmi, Ryan Phan and Katrina Sepulveda

Department of Mechanical Engineering, California State University, Northridge, Northridge, CA 91330, USA; erich.burg.303@my.csun.edu (E.B.); akinwande.akinwunmi.72@my.csun.edu (A.A.); ryan.phan.25@my.csun.edu (R.P.); katrina.sepulveda.801@my.csun.edu (K.S.)

* Correspondence: peter.bishay@csun.edu; Tel.: +1-818-677-7803

In its second year (**2017-18**), SMW SDP made the following achievements:

(1) Two teams presented their research and designs at the AIAA regional student conference at UC Merced. The 11-page technical paper entitled: “*Design and Manufacturing of an SMA-based Seamless Camber Morphing*

UAV Tail Section” won the **second** place (Award certificates and \$300) in the competition after USC and followed by University of Washington in the 3rd place.

(2) Technical paper on the camber morphing tail-section core design was published in *Smart Materials and Structures* journal, entitled “*Development of an SMA-based camber morphing UAV tail core design*”

<https://iopscience.iop.org/article/10.1088/1361-665X/ab1143>

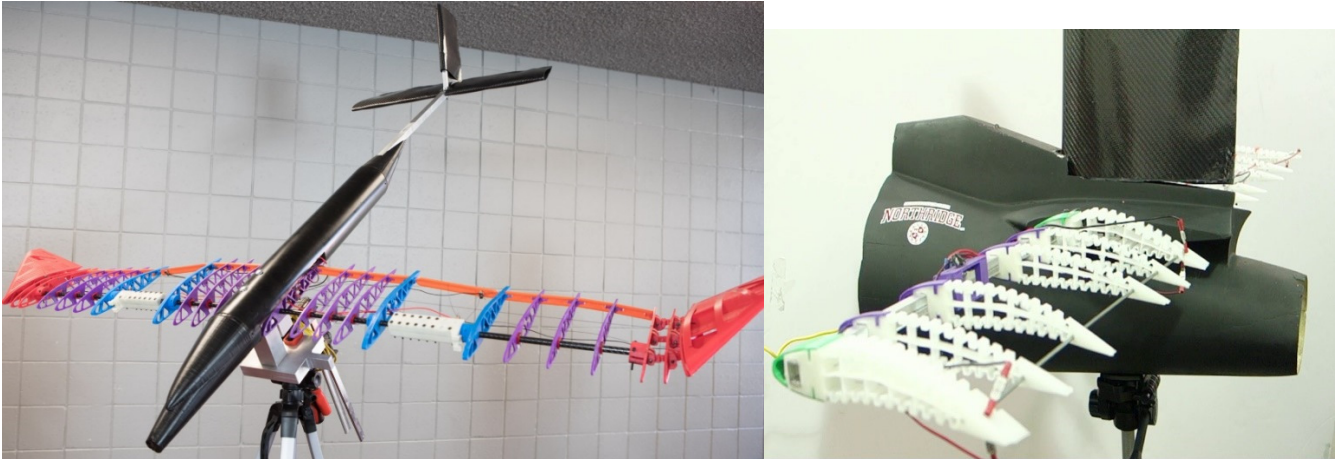

IOP Publishing Smart Materials and Structures
Smart Mater. Struct. **28** (2019) 075024 (11pp) <https://doi.org/10.1088/1361-665X/ab1143>

Development of an SMA-based camber morphing UAV tail core design

Peter L Bishay , Ryan Finden, Shawn Recinos, Christian Alas, Erik Lopez, Dvin Aslanpour, Douglas Flores and Efrain Gonzalez

Department of Mechanical Engineering, California State University of Northridge, Northridge, CA, 91330, United States of America

The goal of the third cohort (2018-19) was to **design, build and fly a fully morphing UAV with span-morphing wings and camber morphing stabilizers**. The team made the following achievements:

- (1) **Second place** (Award certificates and \$300) at the AIAA regional student conference and competition, Cal Poly San Luis Obispo (April 6-7). 11-page technical paper title: *Matamorph 1: A New Experimental UAV with Span-Morphing Wing and Camber-Morphing Tail*.
- (2) **First place** (Award certificates and \$200) at the 10-minute presentation competition of CSUN’s 23rd annual research and creative works symposium (CSUNposium), College of Engineering and Computer Science session.
- (3) **First place** (Award certificates and \$200) at the 3-minute presentation competition of CSUN’s 23rd annual research and creative works symposium (CSUNposium). Presentation title: Wind Tunnel Testing of Two New Morphing Wing Designs.

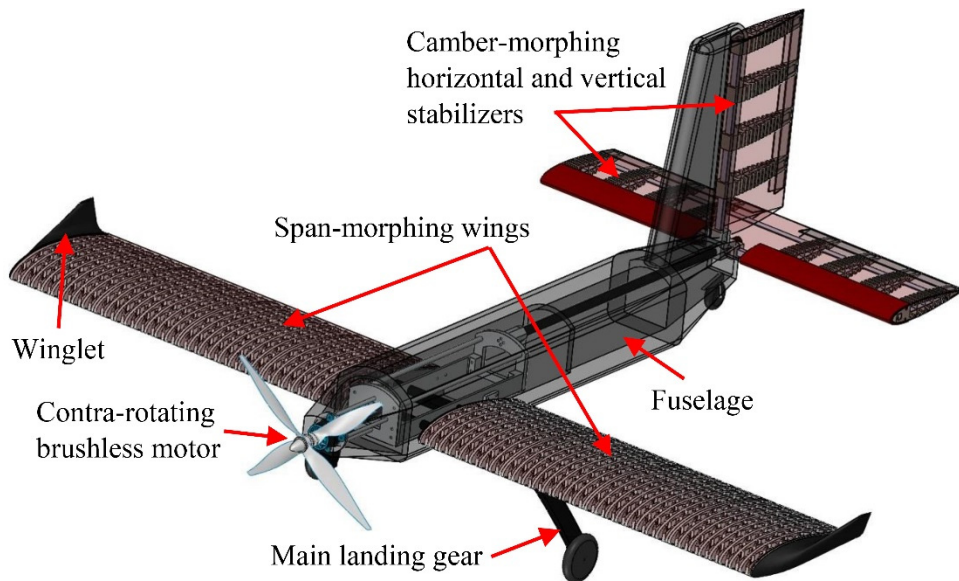

The goal of the fourth cohort (2019-20) is to **design, build and fly a fully morphing UAV with twist-morphing wings and camber morphing stabilizers**. The team made the following achievements:

- (1) **First place** (Award certificates and \$200) at the 10-minute presentation competition of CSUN's 24th annual research and creative works symposium (CSUNposium).
- (2) **First place** (Award certificates and \$200) at the 3-minute presentation competition of CSUN's 24th annual research and creative works symposium (CSUNposium). Presentation title: *Can we fly an airplane with wings that change their shape inflight?*
- (3) **First place** (Award certificates and \$500) at the AIAA regional student research competition. The competition included 13 teams from University of Southern California (USC), Arizona State University (ASU), University of Washington (UW), Portland State University (PSU), Embry-Riddle Aeronautical University and University of Alaska, Fairbanks. After CSUN, a team from UW got 2nd place and a team from USC got third place. [AIAA Announced 2020 Regional Student Conference Winners](#). The team's 11-page technical paper is entitled "*A new experimental UAV with twist-morphing wings and camber-morphing tail stabilizers.*" A team

representative presented the paper at the AIAA 2021 virtual SciTech Forum in January 2021, and the paper was also published as part of the 2021 SciTech conference proceedings.

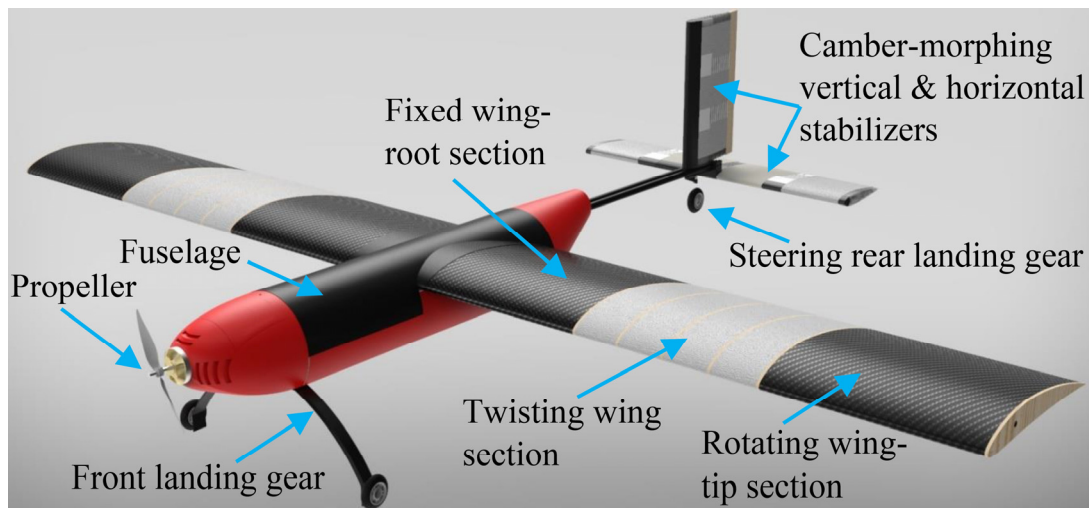

AIAA SciTech Forum
11-15 & 19-21 January 2021, VIRTUAL EVENT
AIAA SciTech 2021 Forum

10.2514/6.2021-0584

 Check for updates

MataMorph 2: A new experimental UAV with twist-morphing wings and camber-morphing tail stabilizers



Adam E. Schlup¹, Tommy L. MacLennan¹, Cristobal Barajas¹, Bianca L. Talebian¹, Gregory C. Thatcher¹, Richard B. Flores¹, Justin D. Perez-Norwood¹, Christian L. Torres¹, Kebron B. Kibret¹, Edgar E. Guzman¹
and
Dr. Peter L. Bishay²
California State University, Northridge, Northridge, CA, 91330, United States

The goal of the fifth cohort (2020-21) was to **design, build and fly a fully morphing UAV with camber-morphing wings and tail stabilizers**. The team made the following achievements:

- (1) **Second place** (Award certificates and \$100) at the 10-minute presentation competition of CSUN’s 25th annual research and creative works symposium (CSUNposium).

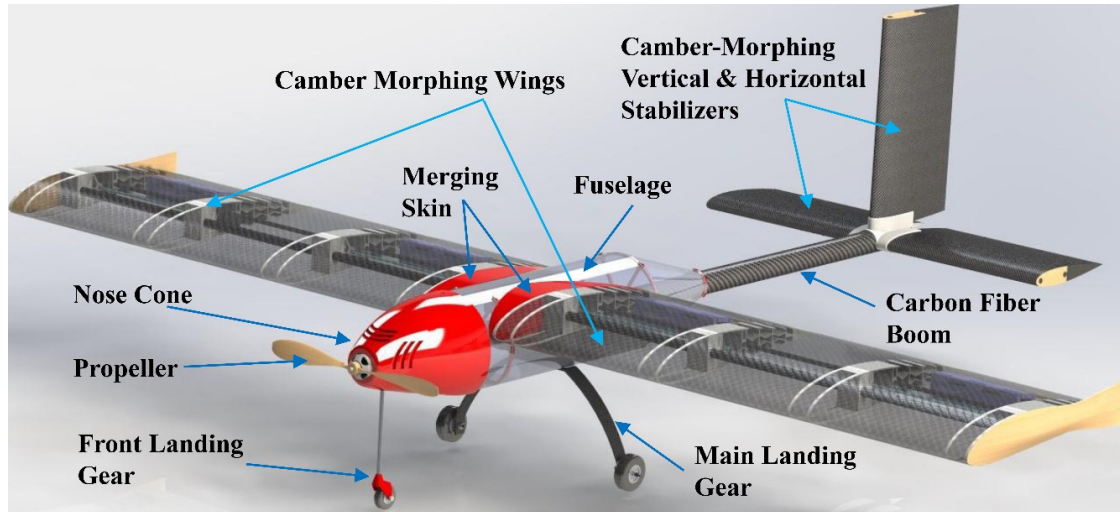
- (2) **Second place** (Award certificates and \$300) at the virtual AIAA regional student research competition. First place went to CalTech’s team and third place to USC’s team. The team’s 11-page technical paper is entitled “*Design and analysis of MataMorph-3: An experimental fully morphing UAV with camber-morphing wings and tail stabilizers.*”
- (3) Only representative of CSUN’s College of Engineering and Computer Science (CECS) at the **2021 CSU Statewide Student Research Competition.**
- (4) Publication of a research paper in Aerospace journal, entitled: [Design and Analysis of MataMorph-3: A Fully Morphing UAV with Camber-Morphing Wings and Tail Stabilizers.](#)



aerospace

Article

Design and Analysis of MataMorph-3: A Fully Morphing UAV with Camber-Morphing Wings and Tail Stabilizers

Peter L. Bishay *, James S. Kok, Luis J. Ferrusquilla, Brian M. Espinoza, Andrew Heness, Antonio Buendia, Sevada Zadoorian, Paul Lacson, Jonathan D. Ortiz, Ruiki Basilio and Daniel Olvera

The scope of SMW changed in 2021-22, and the sixth cohort focused on **designing a camber-morphing wind turbine blade for improved efficiency and load alleviation.** The team made the following achievements:

- (1) Published journal paper at *Journal of Engineering Research*, entitled “SCAMORSA-1: a camber-morphing wind turbine blade with sliding composite skin.”
- (2) Presentation at the 2022 AIAA regional student research conference and competition (UC Merced). The team’s 11-page technical paper is entitled “*SCAMORSA-1: a camber-morphing wind turbine blade with sliding composite skin.*”

- (3) **First place** (Award certificates and \$200) at the poster competition of CSUN's 26th annual research and creative works symposium (CSUNposium). Poster title: *Design of a Camber Morphing Wind Turbine Blade for Load Alleviation and Improved Aerodynamic Efficiency*.
- (4) The team presented at CSUN's 2022 College of Engineering and Computer Science Senior Design Project Showcase (SDPS).

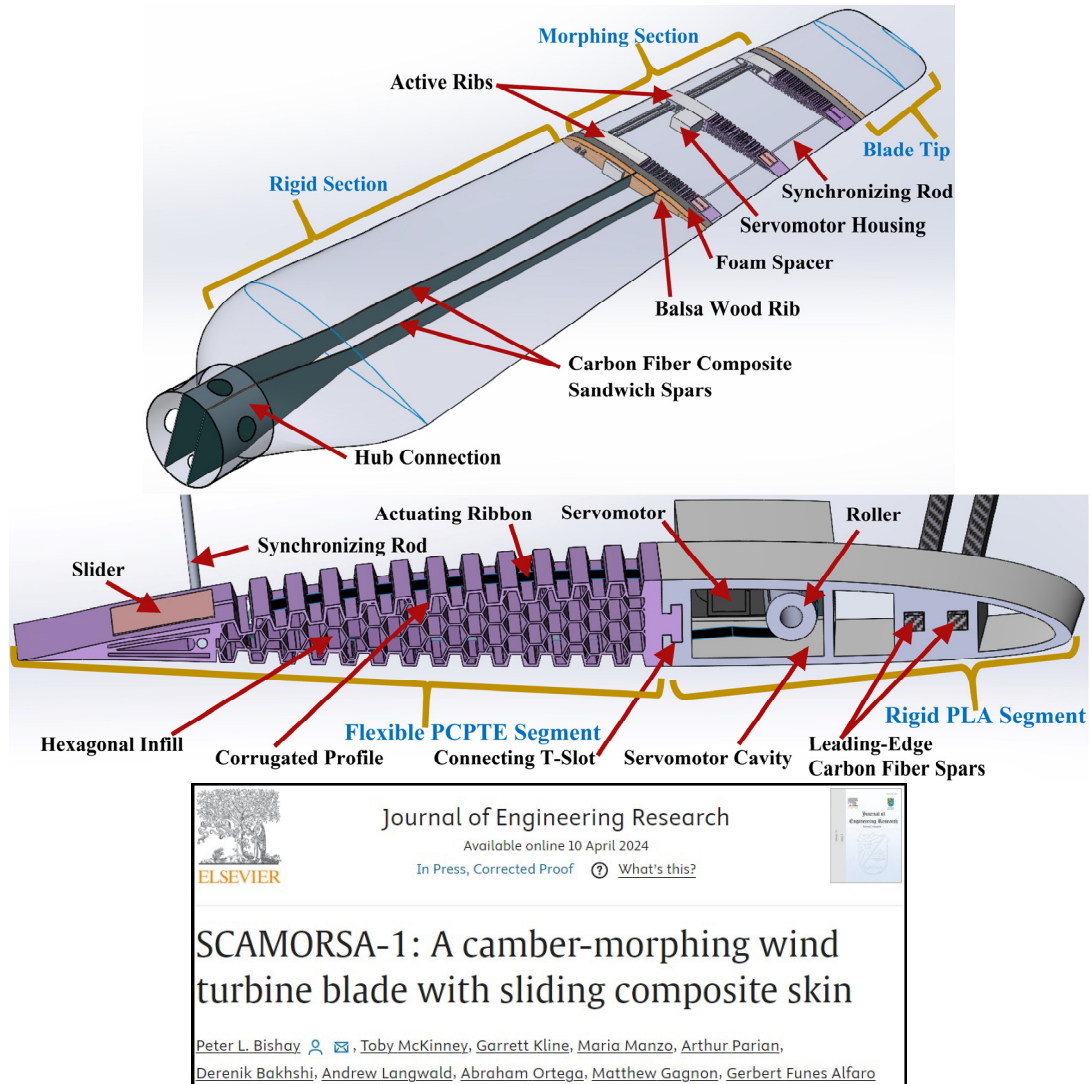

The seventh cohort (2022-23) designed a bio-inspired bird-like non-flapping unmanned aerial vehicle (UAV), called “MataGull”. The flexible wing and tail morphing mechanisms were presented in an *Applied Sciences* journal paper. They made the following achievements:

- (1) Honorable mention at the AIAA regional student research conference and competition (UC Davis, March 25-26, 2023). Technical paper title: "*MataGull: A lightweight bio-inspired non-flapping bird-like morphing drone*". Paper published at AIAA ARC.
- (2) **First place** (Award certificates and \$300) at the 10-minute presentation competition of CSUN's 27th annual research and creative works symposium (CSUNposium). Presentation title: MataGull, a bio-

- (3) inspired lightweight non-flapping bird-like morphing drone.
- (4) Mechanical Engineering **Project Display Winner** at CSUN's 2023 College of Engineering and Computer Science Senior Design Project Showcase (SDPS) (Award certificates and \$500).
- (5) **Paper publication:** Bishay, P. L.; Brody, M.; Podell, D.; Corte Garcia, F.; Munoz, E.; Minassian, E.; Bradley, K. (2023): [3D-Printed Bio-Inspired Mechanisms for Bird-like Morphing Drones](#) *Applied Sciences*, Vol. 13(21), 11814, DOI: 10.3390/app132111814.



applied
sciences



Article

3D-Printed Bio-Inspired Mechanisms for Bird-like Morphing Drones

Peter L. Bishay ^{*}, Matthew Brody, David Podell, Francisco Corte Garcia, Erik Munoz, Evette Minassian and Kevin Bradley

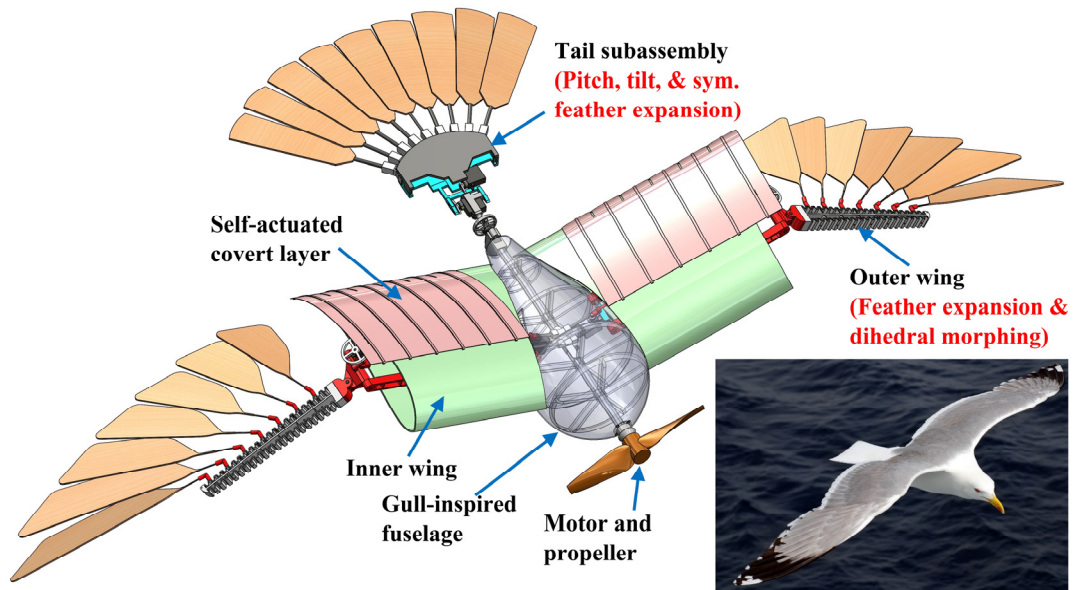

The eighth cohort (2023-24) designed CGull, a bio-inspired bird-like non-flapping unmanned aerial vehicle (UAV), that is entirely made of composite shells. They made the following achievements:

- (1) **First place** at the AIAA regional student research conference and competition (Santa Clara University, March 23-24, 2024). Technical paper title: "*Design of a non-flapping seagull-inspired composite morphing drone*". Paper published at AIAA ARC.
- (2) **First place** (Award certificates and \$300) at the 10-minute presentation competition of CSUN's 28th annual research and creative works symposium (CSUNposium). Presentation title: *CGull: A bio-inspired non-flapping bird-like morphing drone*.
- (3) Mechanical Engineering **Project Display Winner** at CSUN's 2024 College of Engineering and Computer Science Senior Design Project Showcase (SDPS) (Award certificates and \$500).
- (4) Presentation at *the 1st International Online Conference on Biomimetics*, May 15-17, 2024 (by Dr. Bishay). Presentation title: *CGull: A Non-Flapping Seagull-Inspired Composite Morphing Drone*.
- (5) Manuscript prepared for publication in *Biomimetics* journal.

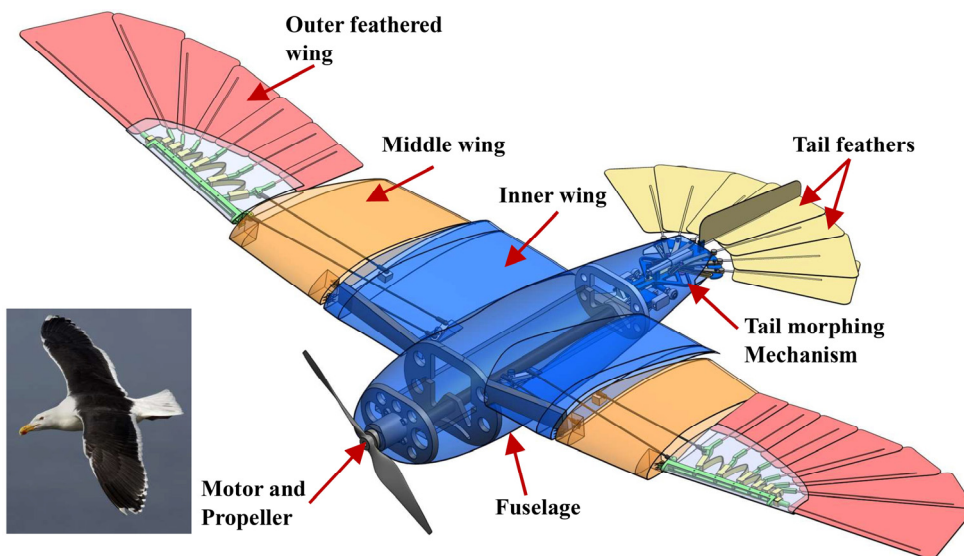

Design of a non-flapping seagull-inspired composite morphing drone

Moises Brambila¹, Alex Rini¹, Jordan Eghdamzamiri¹, Hariet Yousefi¹, Joshua Herrera¹, Donovan Hanna¹, Caleb Black¹, Youssef Saad¹, Aramar Arias-Rodas¹
and
Peter L. Bishay²

Department of Mechanical Engineering, California State University, Northridge

Table 1: SMW achievements table

| Cohort | AIAA competition | CSUNposium | | Other |
|--|-----------------------|--|-----------------------|--|
| | | 10-min | 3-min | |
| First (2016-17) | 3 rd place | 1 st & 2 nd places | - | Paper in <i>Designs</i> journal. |
| Second (2017-18) | 2 nd place | - | 1 st place | Paper in <i>Smart Materials & Structures</i> journal. |
| Third (2018-19): XM1 | 2 nd place | 1 st place | 1 st place | |
| Fourth (2019-20): XM2 | 1 st place | 1 st place | 1 st place | Paper in <i>AIAA SciTech Conference</i> Proceedings. |
| Fifth (2020-21): XM3 | 2 nd place | 2 nd place | - | - Only representative of CSUN's CECS in the 2022 CSU-statewide competition. - Paper in <i>Aerospace</i> journal. |
| Sixth (2021-22): SCAMORSA-1 wind turbine blade | - | - | - | - 1 st place: CSUNposium Poster. - Paper in <i>Journal of Engineering Research</i> |
| Seventh (2022-23): MataGull | Honorable Mention | 1 st place | - | - 1 st place: Project Display at Senior Design Project Showcase . - Paper in <i>AIAA ARC</i> . - Paper in <i>Applied Sciences</i> . |
| Eighth (2023-24): CGull | 1 st place | 1 st place | - | - 1 st place: Project Display at Senior Design Project Showcase . - Paper in <i>AIAA ARC</i> . - Presentation at <i>the 1st International Online Conference on Biomimetics</i> . - Paper to be submitted in <i>Biomimetics</i> . |

The scope of the ninth cohort (2024-25) will be to **improve the design of CGull (a bio-inspired bird-like non-flapping unmanned aerial vehicle (UAV))**.

For more details, visit: <http://www.csun.edu/~pbishay/projects.php>.



1.2 Smart Prosthetics

Smart Prosthetics SDP started in 2017-18 academic year with the goal of designing biomimetic innovative prosthetic hand model based on smart materials and structures (such as Shape Memory Alloy (SMA) wires, Twisted and Coiled Polymer (TCP) wires, Smart Soft Composites (SSC), etc.). The enrolled students get involved in reading recent research papers on the current advances in this technology, propose analytical and computational models, run computer simulations on their models to justify their designs, physically build their innovative models, test their performance and present their work at several events such as the American Society of Biomechanics (ASB) regional meetings, CSUN's annual research and creative works symposium (CSUNposium), and CSUN's Senior Design Project Showcase (SDPS). Preliminary and Critical Design Review (PDR and CDR) are scheduled in the Fall semester, where students get the chance to receive feedback from industry professionals, faculty members, graduate students and peer undergraduate students. Students also give biweekly presentations and write monthly reports throughout the semester.

In its first year (**2017-18**), Smart Prosthetics SDP made the following achievements:

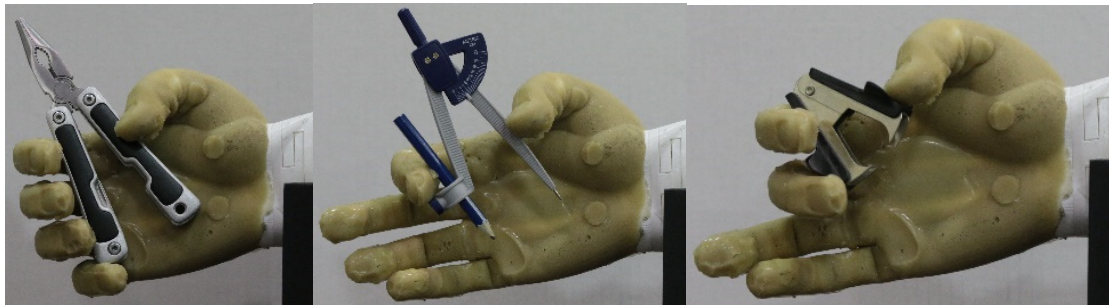
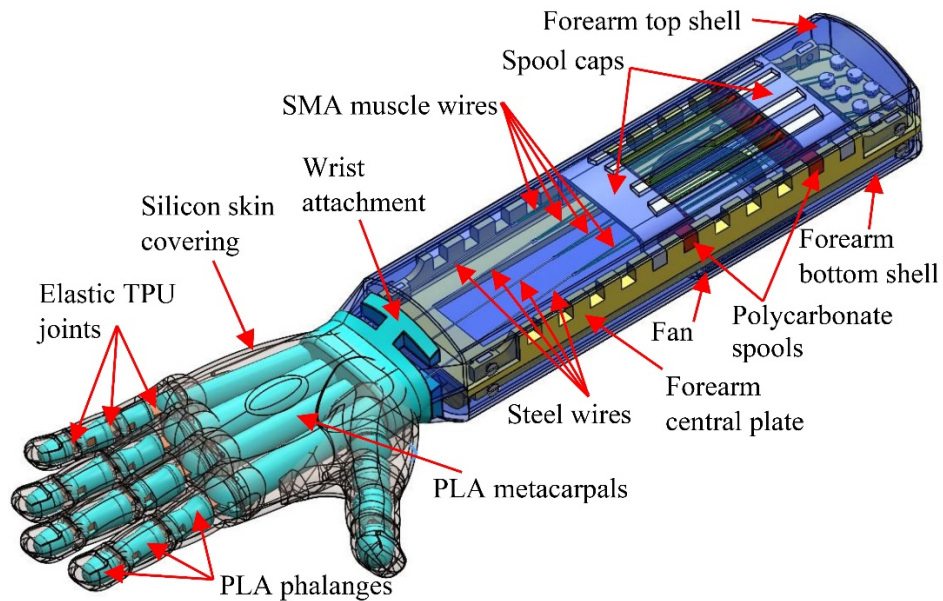
- (1) **Grand Prize** Winner (\$1000), Mechanical Engineering Oral Presentation Winner (\$500) and Project Display Winner (\$500) at CSUN's 2018 College of Engineering and Computer Science Senior Design Project Showcase (SDPS).
- (2) **First** place (Award certificates and \$200) at the oral presentation competition of CSUN's 22nd annual research and creative works symposium (CSUNposium), College of Engineering and Computer Science session. Presentation title: "*Development of a New, Innovative, Smart Prosthetic Hand*".
- (3) Poster presentation at the 8th annual Rocky Mountain American Society of Biomechanics (RMASB) regional meeting (April 13-14, 2018, Estes Park, CO).
Extended Abstract available at: http://www.csun.edu/~pbishay/pubs/SP_RMASB_2018.pdf
- (4) Poster presentation at the 14th annual Northwestern American Society of Biomechanics (NWASB) regional meeting (May 4-5, 2018, Bellingham, WA).
Extended Abstract available at: http://www.csun.edu/~pbishay/pubs/SP_NWASB_2018.pdf
- (5) Technical paper published in *Engineering Research Express* journal, entitled "***Development of a biomimetic transradial prosthetic arm with shape memory alloy muscle wires.***"
<https://iopscience.iop.org/article/10.1088/1361-665X/ab1143>



| | | |
|---|---|---|
| IOP Publishing | <i>Eng. Res. Express</i> 2 (2020) 035041 | https://doi.org/10.1088/2631-8695/abb710 |
| | Engineering Research Express | |
|  CrossMark | PAPER | |
| | Development of a biomimetic transradial prosthetic arm with shape memory alloy muscle wires | |
| RECEIVED 24 June 2020 | | |
| REVISED 20 August 2020 | | |
| ACCEPTED FOR PUBLICATION 10 September 2020 | | |
| PUBLISHED 28 September 2020 | Peter L Bishay  , Jonathan Fontana, Bret Raquipiso, Julian Rodriguez, M Justin Borretta, Bethany Enos, Thomas Gay and Kevin Mauricio | |
| | California State University, Northridge, Northridge, 91330, United States of America | |
| | E-mail: peter.bishay@csun.edu | |
| | Keywords: upper-limb prostheses, smart materials, 3D printing | |
| | Supplementary material for this article is available online | |

The goal of the second cohort (2018-19) was to **design, build and test an affordable lightweight below-the-elbow prosthetic hand with better functionality, controllability and power consumption.** The team made the following achievements:

- (1) Mechanical Engineering **Oral Presentation Winner** (\$500) at CSUN's 2019 College of Engineering and Computer Science Senior Design Project Showcase (SDPS).

- (2) **First place** (Award certificates and \$200) at the 10-minute presentation competition of CSUN's 23rd annual research and creative works symposium (CSUNposium). Presentation title: *Development of a New Lightweight Low-Cost SMA-Based Transradial Prosthetic Arm.*
- (3) **Third place** (\$5,000) at the third CSUN Bull Ring competition.
- (4) Poster presentation at the 9th annual Rocky Mountain American Society of Biomechanics (RMASB) regional meeting (April 5-6, 2019, Estes Park, CO).
- (5) **First place** at the poster presentation competition of CSUN's California Renewable Energy and Storage Technology (CREST) conference (November 10, 2018). Poster title: "*Efficient power systems in shape-memory alloy (SMA) actuated prostheses*".
- (6) Technical paper to appear in 2021 *ASME-SMASIS Conference proceedings*, entitled "*Design of a lightweight shape memory alloy stroke-amplification and locking system in a transradial prosthetic arm.*"

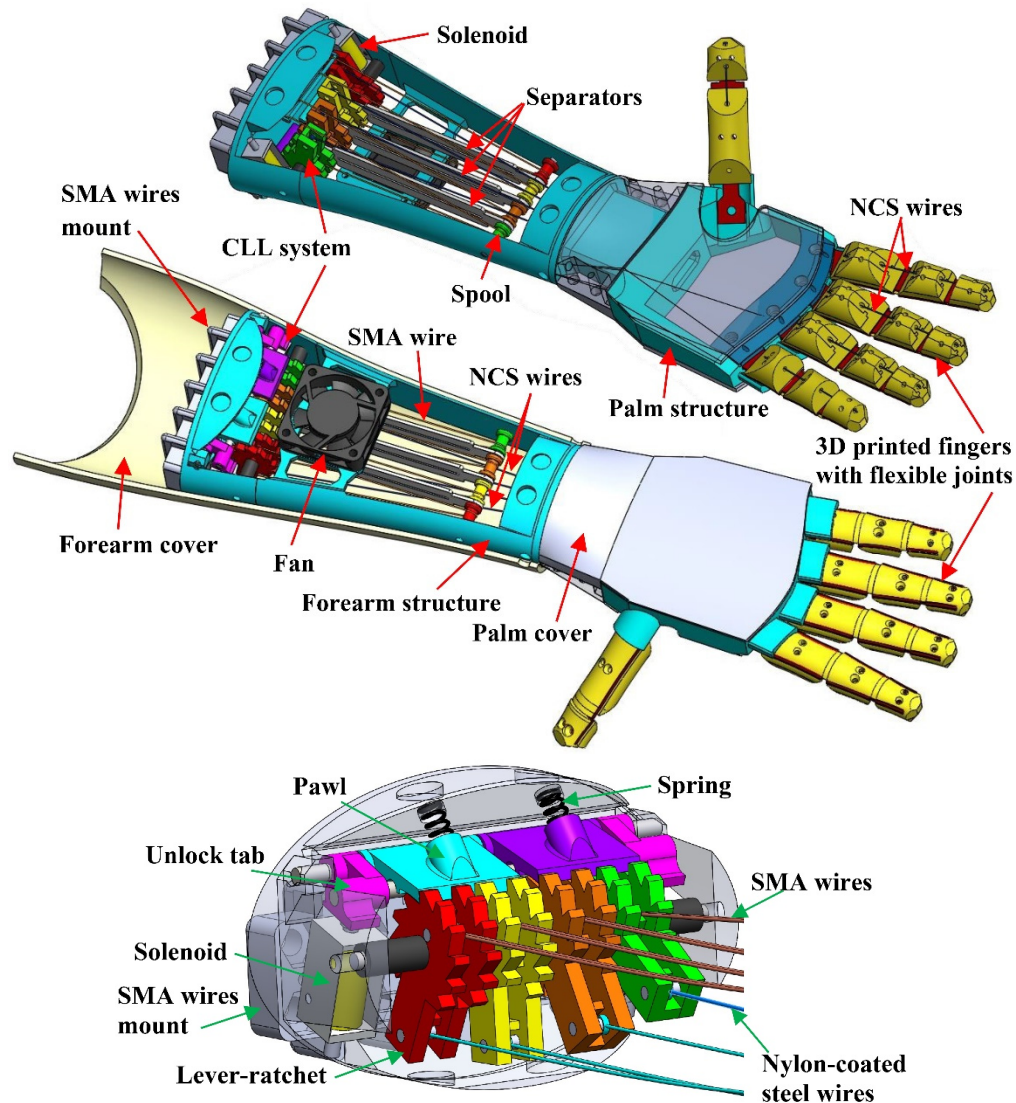



Proceedings of the ASME 2021 Conference on Smart Materials,
Adaptive Structures and Intelligent Systems
SMASIS2021
September 14-15, 2021, Virtual, Online

SMASIS2021-68248

**DESIGN OF A LIGHTWEIGHT SHAPE MEMORY ALLOY STROKE-AMPLIFICATION AND
LOCKING SYSTEM IN A TRANSRADIAL PROSTHETIC ARM**

**Peter Bishay¹, Christian Aguilar¹, Arshak Amirkbekyan¹, Kevin Vartanian¹, Martin Arjon-Ramirez¹,
David Pucio¹**

¹California State University, Northridge, CA, USA

The third cohort (2019-20) designed two prosthetic arm devices: (1) *MyOwn* design that features new finger design with fingertip force sensors, and improved grip performance and (2) *Hall-n-Oates* design that features innovative actuation system as a mechanical computer for adaptive gripping, and works with only one actuator so has very low power consumption. The team presented their research and designs at CSUN's 24th annual research and creative works symposium (CSUNposium) and CSUN's 2020 College of Engineering and Computer Science Senior Design Project Showcase (SDPS); both events were virtual.



The fourth cohort (2020-21) designed a prosthetic arm called “*Hercules*,” that features wrist rotation mechanism and a tactile feedback system. The team presented their research and designs at CSUN's 25th annual research and creative works symposium (CSUNposium) and CSUN's 2021 College of Engineering and Computer Science Senior Design Project Showcase (SDPS); both events were virtual.

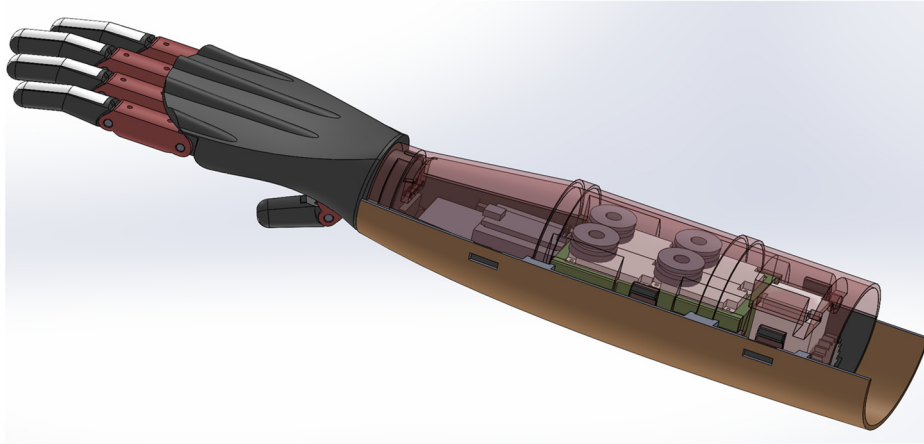

The fifth cohort (2021-22) designed a prosthetic arm called the “*Infinity*” arm, that features wrist bending and rotation mechanism, improved haptic feedback system and a foot controller. The details of the designs were presented in a *Prosthesis* journal paper.

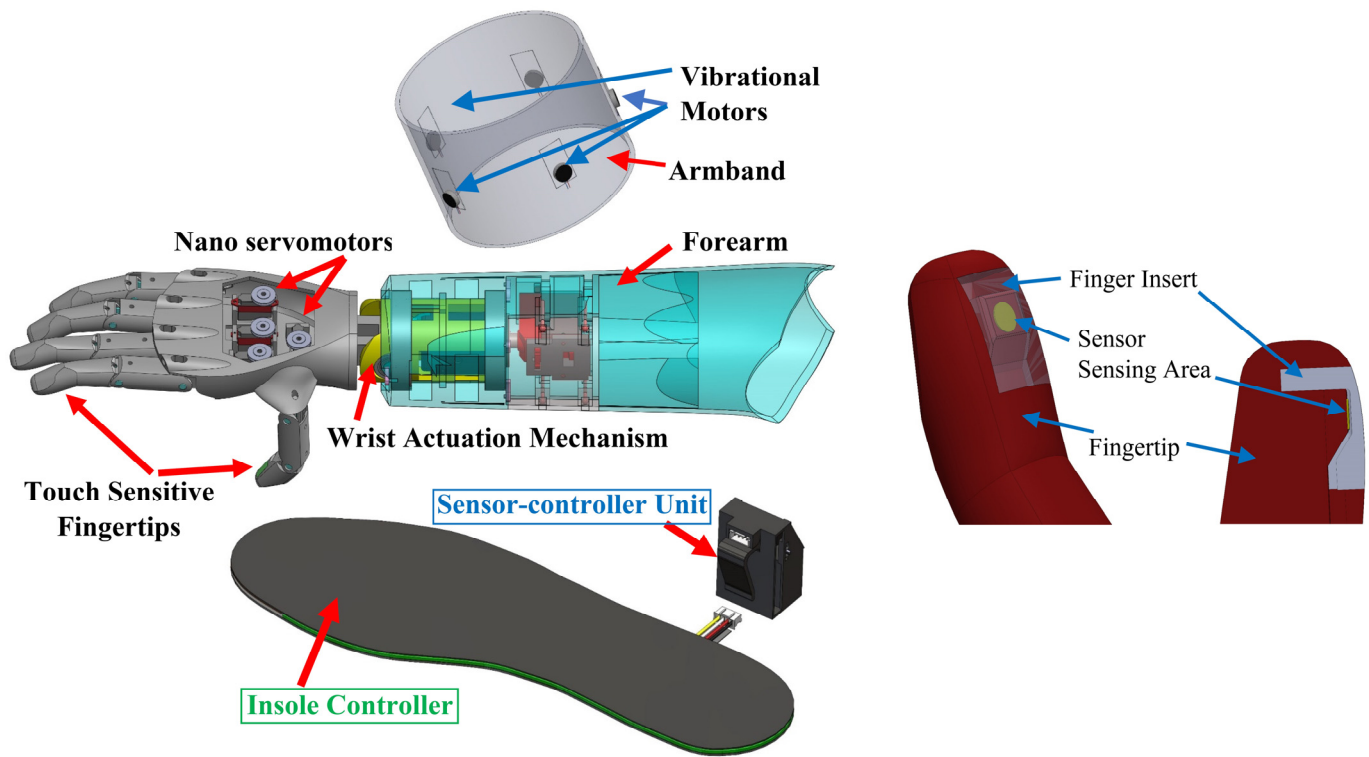



Technical Note

Controlling a Below-the-Elbow Prosthetic Arm Using the Infinity Foot Controller

Peter L. Bishay ^{*}, Jack Wilgus, RunRun Chen, Diego Valenzuela, Victor Medina, Calvin Tan [†], Taylor Ittner, Miguel Caldera, Cristina Rubalcava, Shaghik Safarian, Gerbert Funes Alfaro, Alfredo Gonzalez-Martinez, Matthew Gosparini, Jose Fuentes-Perez, Andy Lima, Jonnathan Villalobos and Abrahan Solis

The team made the following achievements:

- (1) **First place** (Award certificates and \$200) at the 10-minute presentation competition of CSUN's 26th annual research and creative works symposium (CSUNposium). Presentation title: *3D Printed Below-the-Elbow Prosthetic Arm with Foot Control, Wrist Actuation, and Haptic Feedback Systems*.
- (2) Only representative of CSUN's College of Engineering and Computer Science (CECS) at the **2022 CSU Statewide Student Research Competition**.
- (3) The team will present at CSUN's 2022 College of Engineering and Computer Science Senior Design Project Showcase (SDPS).
- (4) Paper publication: Bishay, P. L.; Wilgus, J.; Chen, R.; Valenzuela, D.; Medina, V.; Tan, C.; Ittner, T.; Caldera, M.; Rubalcava, C.; Safarian, S.; Alfaro, G.F.; Gonzalez-Martinez, A.; Gosparini, M.; Fuentes-Perez, J.; Lima, A.; Villalobos, J.; Solis A. (2023): Controlling a Below-the-Elbow Prosthetic Arm Using the Infinity Foot Controller *Prosthesis*, Vol. 5(4), 1206-1231, DOI: 10.3390/prosthesis5040084.

The scope of the sixth cohort (2022-23) was to further improve the hand motion and grasping force of "Infinity" arm and enhance its foot controller and haptic feedback system. "Clock" arm was designed with linkage-based fingers and joystick-actuated foot control.

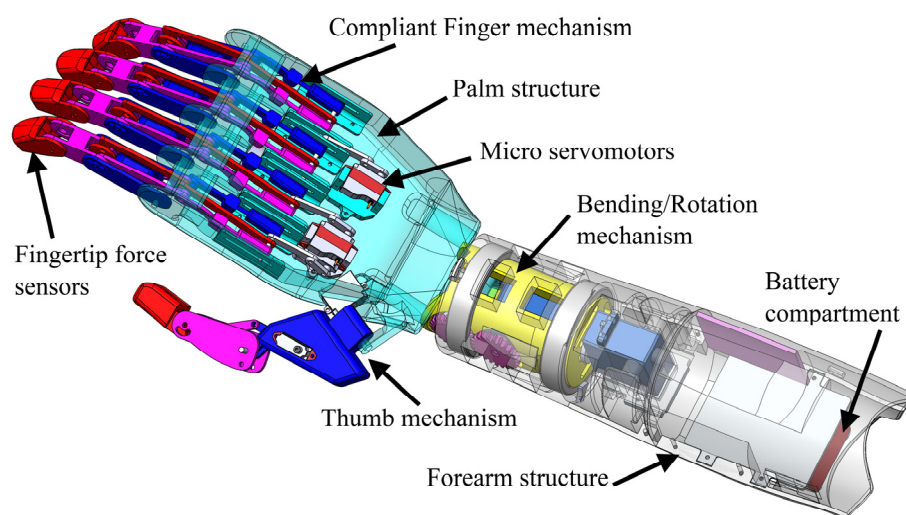

The seventh cohort (2023-24) designed the “Persistence” and the “Precision” arms. Persistence is a tendon-based hand, while Precision is a linkage-based hand, both are connectable to the same forearm design that features wrist rotation and bending mechanism. The foot controller has also been transformed to a sleeve that does not need a shoe to be used, and Bluetooth has been used for communication. The new haptic feedback system is now totally integrated in a sensing glove that can work with any prosthetic hand.

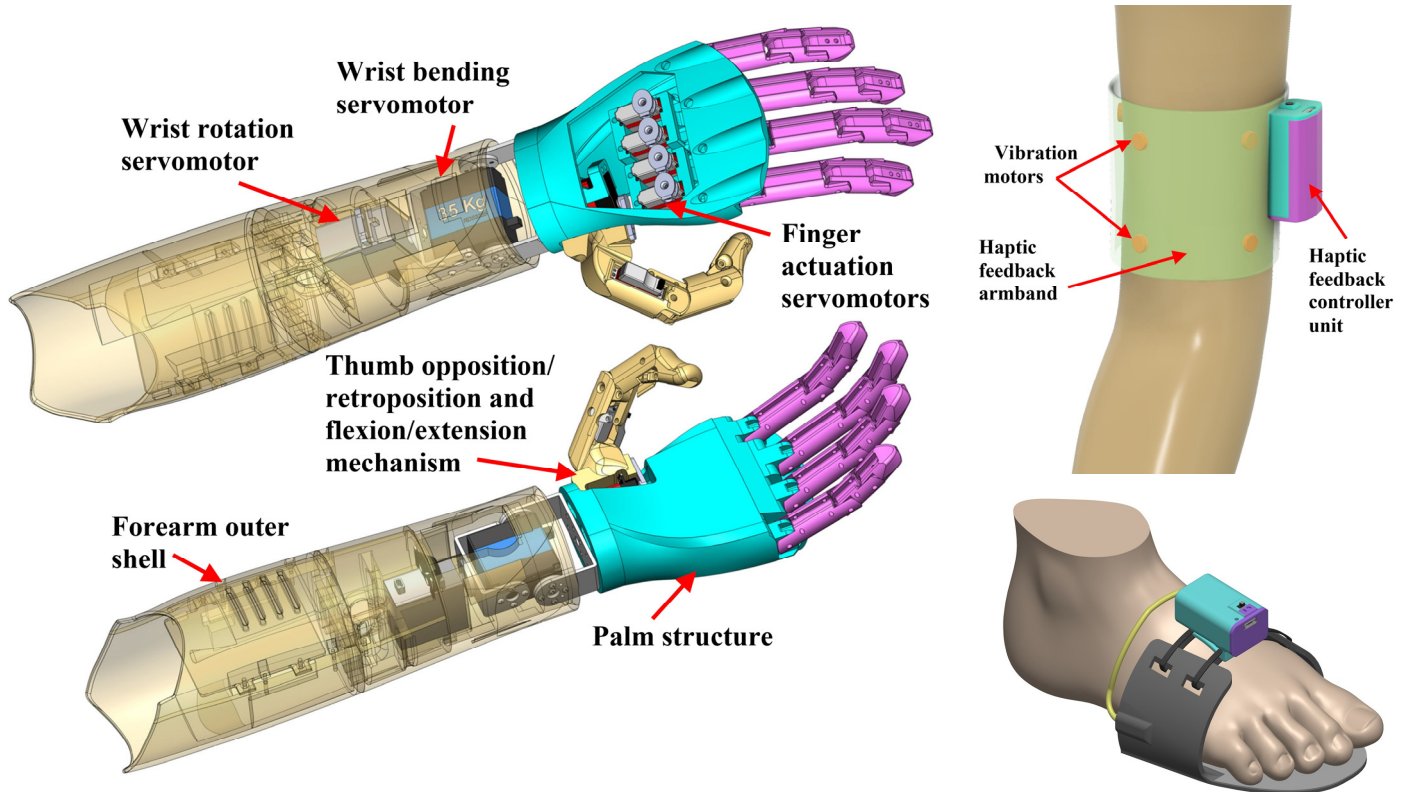

Table 2: SP achievements table

| Cohort | CSUNposium | | Other |
|--|-----------------------|-----------------------|---|
| | 10-min | 3-min | |
| First (2017-18): MataPro-1 | 1 st place | 1 st place | - 1 st place in oral presentation & project display competitions as well as the Grand Prize at SDPS - Posters in RMASB and NWSB symposia - Paper in <i>Engineering Research Express</i> journal |
| Second (2018-19): MataPro-2 | 1 st place | - | - 1 st place in oral presentation competition at SDPS - 3 rd place in CSUN’s Bull Ring competition - Poster in RMASB symposia - Paper in <i>ASME-SMASIS</i> conference proceedings |
| Third (2019-20): MyOwn & Hall & Oates | - | - | |
| Fourth (2020-21): Hercules Arm | - | - | |
| Fifth (2021-2022): Infinity Arm | 1 st place | - | - Only representative of CSUN’s CECS in the 2022 CSU-statewide competition. - Patent application. - Paper in <i>Prosthesis</i> . |

| | | | |
|--|-----------------------|-----------------------|---|
| Sixth (2022-2023): Clock Arm | 2 nd place | - | - Design details were featured in the 5 th cohort's <i>Prosthesis</i> journal paper. |
| Seventh (2023-2024): Infinity-2 Arm | - | 1 st place | - Crowd Favorite Poster Award at the CSU Biotechnology Conference. - 1 st place: CSUNposium Poster. |

The scope of the eighth cohort (2024-25) is to **further improve the finger design and enhance its foot controller and haptic feedback system.**

For more details, visit: <http://www.csun.edu/~pbishay/projects.php> .

2 Enrollment

In order for any student to join “Smart Morphing Wing” or “Smart Prosthetics” SDPs, the following two documents should be sent to Dr. Bishay (peter.bishay@csun.edu) by the end of May:

- 1- Resume (including current GPA, internships, job experience, any projects that the student was part of, special skills, computer software skills, etc.)
- 2- One page essay describing (a) why the student is interested in this SDP specifically, and (b) how does the student qualify to be a part of this research-based SDP.

Around the second week of the summer, Dr. Bishay will inform the selected students by email and will introduce the summer reading assignment (research papers and last year’s technical report). Students are expected to write a report on the assigned readings, and the due date is usually in the first week of the Fall semester. Permission numbers will be given to the selected students a few weeks before the Fall semester.

3 Volunteering

Both senior design projects accept volunteers starting in the winter break and through the Spring semester. Volunteers will be given the opportunity to select the sub-team that they are most interested in working with. Volunteers who perform their assigned tasks as expected will be given preference for enrolment in the following year. Because of the experience volunteers get, they usually lead their senior design projects in the following year. For volunteering, please contact Dr. Bishay or the project leader.

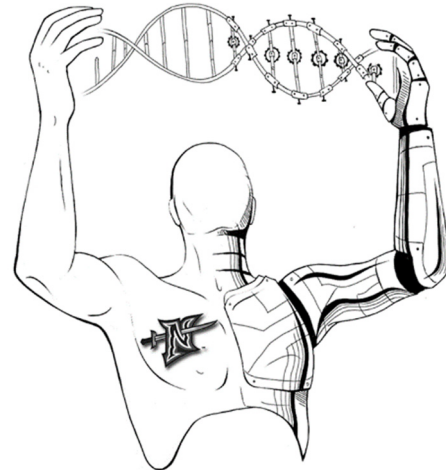
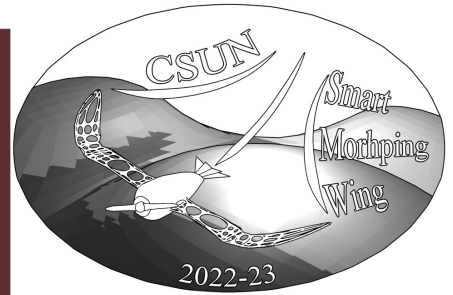

SMART PROSTHETICS

CALIFORNIA STATE UNIVERSITY NORTHRIDGE
2018 - 2019

